

There are many ways of installing tube & fittings and new ideas are always welcome to make on-site fitting much easier. The item below does this by reducing the number of fittings used.

Another conventional design updated is the steam condensate trap set which ordinarily consists of isolation valves, non-return check valve, steam trap & strainer. Spirax Sarco have developed the STS17 pre-fabricated trap set including all of these items with an optional integral sensor where necessary to provide a convenient ready to install trapping solution. Sizes are presently limited to Ø½” to Ø1” which would cover the majority of installations. Details of the set-up are below and are also available on their web site www.spiraxsarco.com

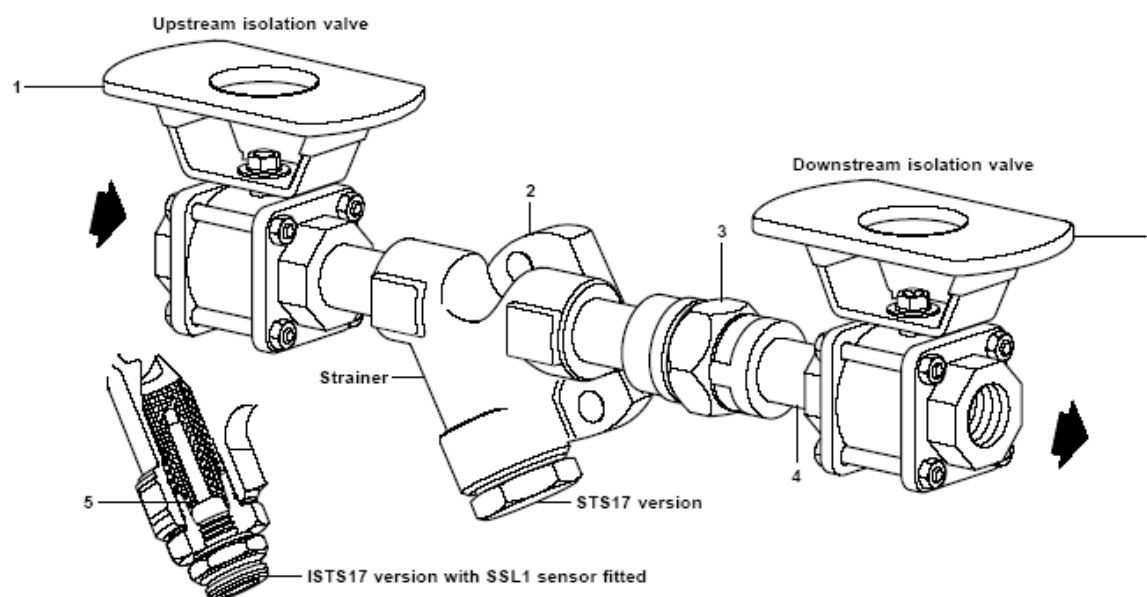

Spirax Sarco STS17

Key Points

- Less maintainable items
- Space saving solution
- Increased product cost but is cheaper overall due to the quicker installation time
- Known fixed cost of arrangement
- Insures correct installation
- Prefabricated, fully welded construction & manufactured from 316L stainless steel
- Does not satisfy double block & bleed applications, additional valves still required

Contact

Mike Capraro
 Project Manager
 Boulting Environmental Services
 Tel: 0161 655 3344
 Fax: 0161 655 3399